

Self-Cleaning Milk Separator MRPX 314 TGV

Application

Separation, standardisation, and clarification of hot milk.
Designed for continuous operation and CIP.

Working Principle

The separator has the following four distinguishing features:

1. Open milk inlet, 2. Paring discs, 3. Automatic sludge discharge, and 4. Cleaning-in-place.

1. Milk Feed. Milk is fed into the separator bowl from the top through a stationary pipe A. Inside the distributor B the milk finds its own level depending on feed capacity and outlet pressures. The milk is smoothly accelerated through the centricyclone C and by the time it enters the disc stack it has achieved almost bowl speed. This gentle acceleration eliminates shattering of the fat globules and prevents air being picked up. Both these facts improve the skimming performance of the separator.

2. Paring Discs. The milk and cream outlet flow is achieved by means of paring discs D and E.

3. Automatic Sludge Discharge. Sludge collecting in the conical sludge space of the bowl is automatically discharged at preset intervals. This is achieved by the sliding bowl bottom F dropping briefly (< 1 second) allowing the sludge to be ejected without disturbing the feed. The opening and closing of the bowl is done with water and controlled by a programme system unit. The bowl opens for such a brief instant that only the sludge escapes (partial discharge). During cleaning the bowl may also be opened long enough for the entire contents to be ejected (total discharge).

4. Cleaning-In-Place. The machine is designed for cleaning-in-place and should be incorporated in the plant automatic CIP system. During the water rinsing phases of the cleaning cycle total discharges are effected, while during the detergent phases partial discharges only are employed in order to save detergent. All parts of the separator in contact with milk as well as the outside of the bowl, the inside of the frame hood, and the sludge outlet are cleaned perfectly without the need for any manual labour.

Basic Unit

Material. The upper part of the machine and all parts in contact with milk are of acid-resistant stainless steel. The motor casing and sludge cyclone are also of stainless steel, and the lower part of the frame is encased in stainless steel.

Standard Equipment. Included are motor, foundation plate, revolution counter, manual brake, and cyclone to absorb the kinetic energy of the ejected sludge.

A spare parts kit is also provided.

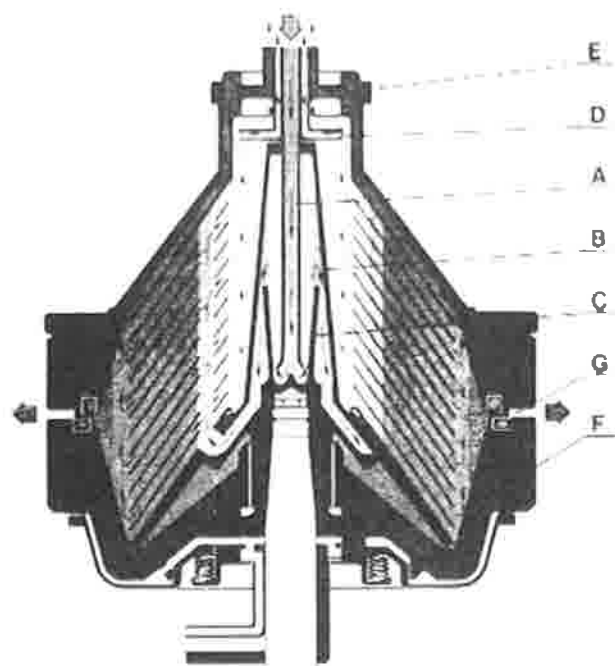
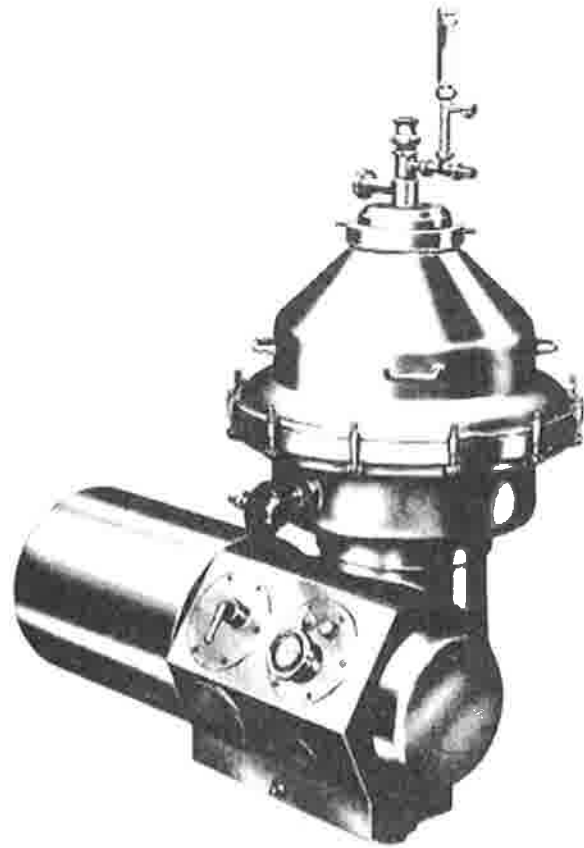

Longitudinal section through bowl shown in closed position

- | | |
|----------------------------|-------------------------------|
| A Inlet pipe | E Skimmilk outlet paring disc |
| B Distributor | F Sliding bowl bottom |
| C Centricyclone | G Sludge ejection ports |
| D Cream outlet paring disc | |

MRPX 314 TGV-74 C

Technical Data

Capacity. Hot milk separation: 15,000 l/h. (Standardisation and clarification: 21,000 l/h).

Connections. Inlet 51 mm. Skimmilk outlet 51 mm. Cream outlet 25 mm. SMS unions.

Motor. 22 kW flange motor for 380/660 V, 50 or 60 Hz 3-phase AC. (Other voltages on request). Motor drives separator bowl directly via worm gear (controlled torque motor).

Bowl Speed. 5,000 rpm.

Sludge Space. 9.6 l.

Water Consumption. Operating water: Intermittent flow of up to 2.5 l/s (max. 4 seconds) at constant pressure of 400 kPa (4 kp/cm²) corresponding to 2 l per partial discharge, 10 l per total discharge, and up to 50 l/h for make-up water. Sludge flushing water: 25 l per discharge. Transmission oil cooling water: Up to 150 l/h.

Air Consumption. None by basic unit.

Inlet Pressure. 40–60 kPa (0.4–0.5 kp/cm²).

Outlet Pressure. 500 kPa (5 kp/cm²) in skimmilk outlet.

Overhead Hoist for 10 kN (1000 kp) is required

Dimensions

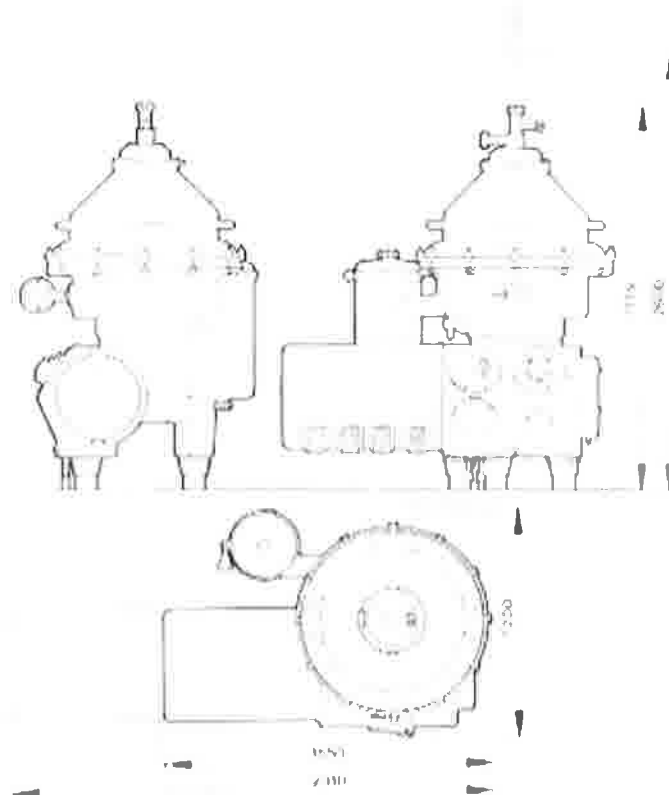

Shipping Data

Basic unit;	without motor	motor only
Net weight, appr	1,350 kg	360 kg
Gross weight, appr	1,650 kg	440 kg
Volume appr	4 m ³	0.6 m ³

Auxiliary Equipment necessary for operation

Item No	Description	Cannot be combined with Item No	Requires Item No	See PD No
1	Set of tools (one set for every three machines)			
3	Cream flow meter			60686
4	Flow controller			60687
15.1	Manual regulating valve on skimmilk outlet + SRC shut-off valve (CIP), adapted to DPE 53	14.2 16 18.2 19.2 20.2	18.1	60691
15.2	Ditto, adapted to DPE 74	14.2 16 18.1 19.1 20.1	18.2	60691
16.1	Constant pressure unit on skimmilk outlet with CIP shut-off, adapted to DPE 53	14 15 18.2 19.2 20.2	18.1	60692
16.2	Ditto, adapted to DPE 74	14 15 18.1 19.1 20.1	18.2	60692
18.1	Discharge programme system equipment DPE 53	19.2 20.2		60694
18.2	Ditto, DPE 74	19.1 20.1		60702

Note: Items 15 and 16 are alternatives to one another.

Optional Equipment

Item No	Description	Cannot be combined with Item No	Requires Item No	See PD No
2	Inlet flow meter			60685
13	Remixing device	3 14 16	15	60688
14.1	Standardising device, manual	3 13 16	15	60689
14.2	Ditto, automatic	3 13 15 16		60690
17	Constant pressure unit for operating water		18	60693
19.1	Air brake instead of manual brake, adapted to DPE 53	18.2 20.2	18.1	60695
19.2	Ditto, adapted to DPE 74	18.1 20.1	18.2	60695
20.1	Remote speed control, adapted to DPE 53	18.2 19.2	18.1	60696
20.2	Ditto, adapted to DPE 74	18.1 19.1	18.2	60696
23	Y/D starter			60718
24	Tripping device			60719
28	Extra spare parts (for 6,000–9,000 hours running)			

This product description does not constitute a binding quotation except in respect of such items and data as are stated in the quotation box (if any) applied to the top of page one